

Front Suspension:

Ride Height: 15mm

Camber: -1

Toe: 0

Arm Type: Gullwina

Tower Type: Gullwina

Caster Block Insert: +5

Steering Block: 4mm

Bulkhead Type: Plastic

Kick-Up Angle: 25

Wheel Hex: 5.0mm

Notes:

Anti Roll Bar:

White (0.8mm)

Gray (0.9mm)

Blue (1.0mm)

Other: None

Bump Steer Spacing: 0mm

Axle Height:

+3

+2

+1

0

Ball Stud Spacing: 2mm

Steering Plate: Kit

Steering Stop Spacing: 0

Ball Stud Spacing: 2mm

Caster Block Spacing: 1mm

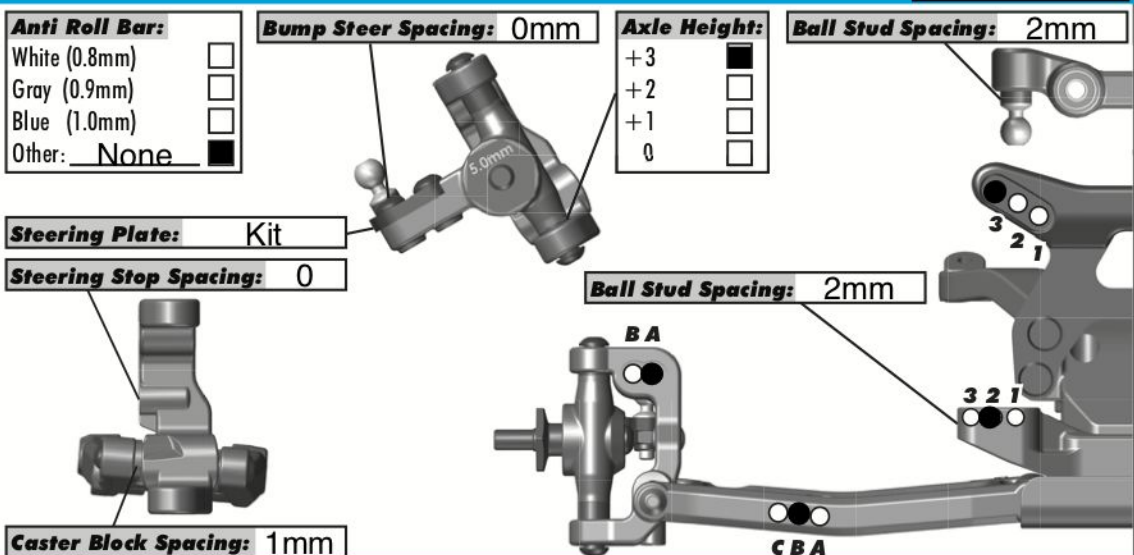

Rear Suspension:

Ride Height: 16mm

Camber: -1

Tower Type: Stock

Wheel Hex: 6.0mm

CVA Bone Length: Stock

CVA Pin Location: Stock

Hub Spacing:

Forward Middle Back

Shock Mounting Position:

Front of Arm Rear of Arm

Notes:

Anti Roll Bar:

White (1.2mm)

Gray (1.3mm)

Blue (1.4mm)

Other: None

Rear Hub Link Setting:

Plastic Hub Aluminum Hub Ball Stud Spacing: 3mm

Up:

Down:

C Mount Inserts: 1° 0.5°

Aluminum Brass

D Mount Inserts: 1° 0.5°

Aluminum Brass

Hub Insert:

+3 +2 +1 0

Ball Stud Spacing: 3mm

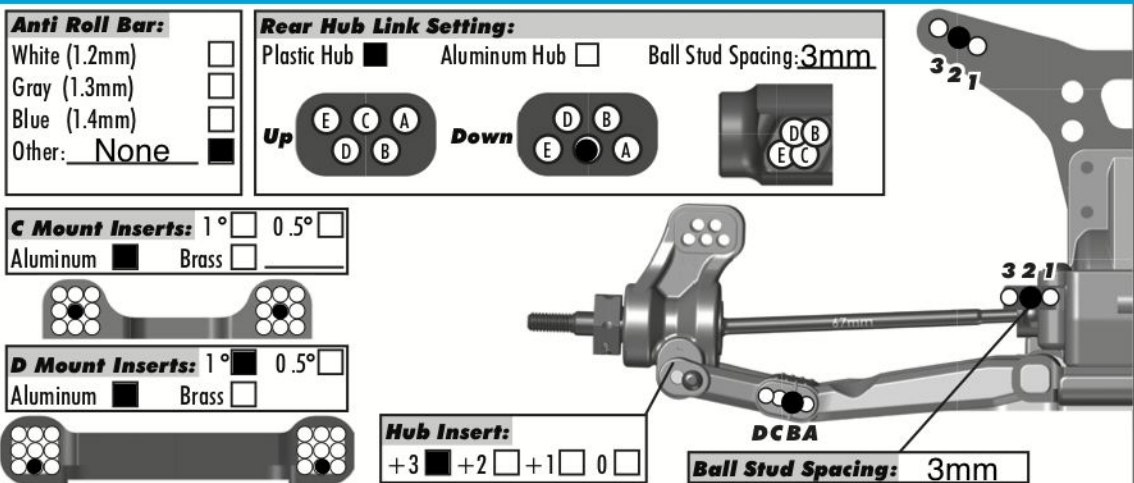

Electronics:

Radio: Sanwa **Servo:** ProTek 160

EPA: Throttle: 100 % Brake: 85 %

ESC: Maclan MMAX Pico 100A

ESC Settings:

Motor: MRR Team Edition V2

Wind: 17.5T **Timing:** 48

Pinion: 30T **Spur:** 72T

Battery: ProTek 4900 Shortv

Battery Position: Forward

Drivetrain:

Transmission: **Laydown:**

3 Gear: **Layback:**

4 Gear: **Stand Up:**

Differential: **Ball Diff:**

Height: 2mm **Gear Diff:**

Notes: 7k fluid - 4 gear

Slipper Clutch:

Type: ASC91800 Elinmina

of Pads:

Shocks:

	Front	Rear
Piston:	2 x 1.6	2 x 1.7
Fluid:	37.5wt	27.5wt
Spring:	V2 Red	V2 White
Limiters:	0	0
Stroke:	21mm	27.5mm
Eyelet Length:	Lona	Lona
Cup Offset:	+5	+5
Notes:		



Track Info:

Size: Small Medium Large Extra Large

Surface: Dirt Carpet AstroTurf Multi Surface

Traction: Low Medium High Very High

Moisture: Dry Damp Wet

Condition: Indoor Outdoor Dusty Hard Packed

Bumpy Grooved Smooth Loamy

Temperature: Ambient: Track:

Notes:

Tires:

Front Tires: Schumacher Cut Sta

Front Compound: Yellow

Front Insert: None (pre-mounted)

Rear Tires: Schumacher Min Da

Rear Compound: Yellow

Rear Insert: Stock (pre-mounted)

Wheel (F/R): Schumacher pre-m

Notes:

Body, Wing, Weight:

Body: Kit

Wing: Pro-Line PRO6294-17

Wing Angle: 0° 3° 6°

Servo Weights:

None Aluminum Steel Other

Electronic Weights:

None Aluminum Steel Other

Total Vehicle Weight:

Vehicle Comments:

Notes: Car is easier to drive without swab bars. If arip is high and you want a more adreasive car. put the stoc